

EXAMPLE: Typical Arrangement of Extrusion Tooling in the Press

Hollow (Porthole) Die Tooling Arrangement

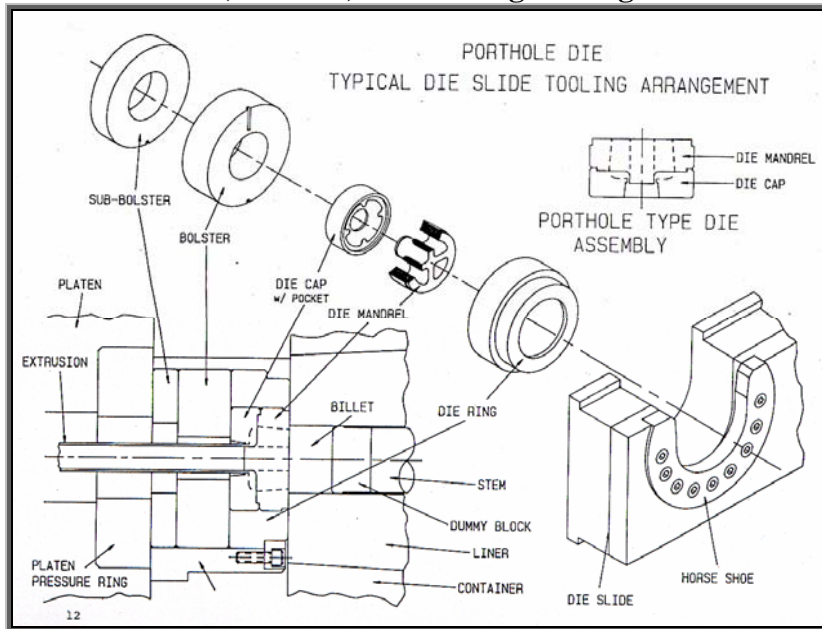

Flat (Solid) Die with Feeder Tooling Arrangement

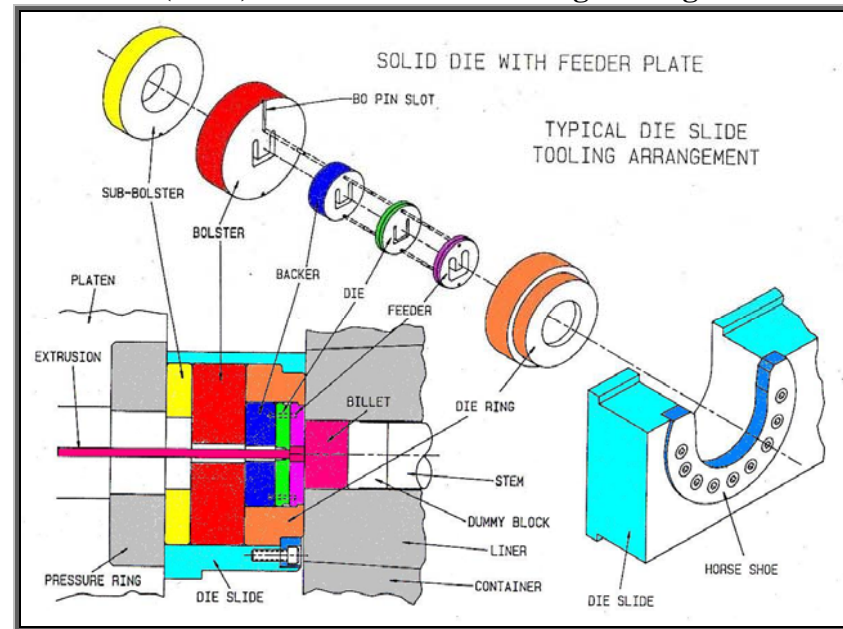

Flat (Solid) Die with Cavity Tooling Arrangement

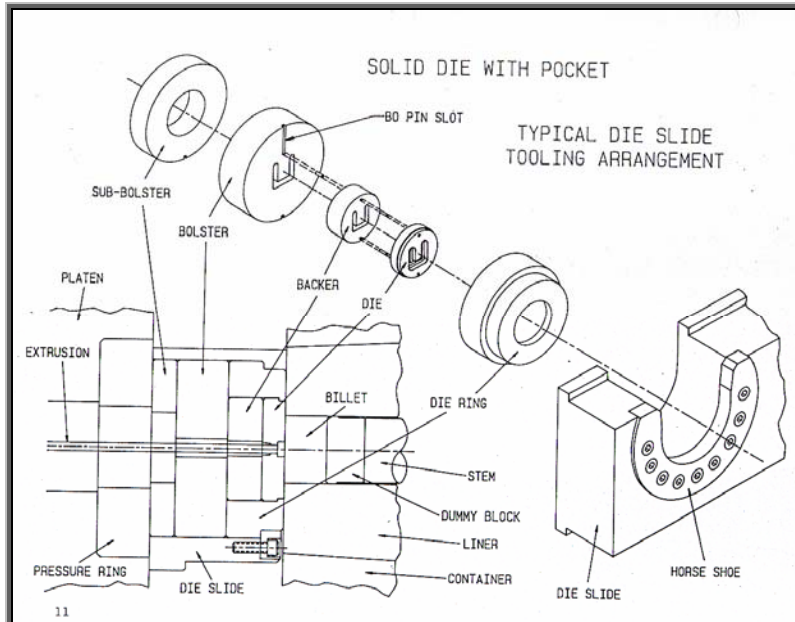

Flat (Solid) Die, no cavity or feeder, Tooling Arrangement

